

TMR7304

Board Mount Precision Current Sensor

Description

TMR7304 is a close loop current sensor for accurate measurement of DC, AC, pulsed current and arbitrary waveform current with galvanic isolation between primary and secondary circuits.



TMR7304-B

TMR7304-C

Features and Benefits

- High accuracy
- Excellent linearity
- Low temperature coefficient
- Fast response time
- Galvanic isolation
- RoHS & REACH compliant

Applications

- Solar inverter
- Direct-current dynamo
- Uninterruptible power supplies (UPS)
- Switched model power supplies (SMPS)
- Variable frequency drive (VFD)



TMR7304-D

TMR7304-E

Selection Guide

Part Number	Primary Nominal Current	Primary Current Range	Contour Difference
TMR7304-0060B	6 A	±20 A	Number of busbars: 3, Number of pins: 3
TMR7304-0150B	15 A	±51 A	
TMR7304-0250B	25 A	±85 A	
TMR7304-0500B	50 A	±150 A	
TMR7304-0060C	6 A	±20 A	Number of busbars: 3, Number of pins: 4
TMR7304-0150C	15 A	±51 A	
TMR7304-0250C	25 A	±85 A	
TMR7304-0500C	50 A	±150 A	
TMR7304-0060D	6 A	±20 A	Number of busbars: 4, Number of pins: 4
TMR7304-0150D	15 A	±51 A	
TMR7304-0250D	25 A	±85 A	
TMR7304-0500D	50 A	±150 A	
TMR7304-0750E	75 A	±180 A	Number of busbars: 5, Number of pins: 4

Insulation and Environmental Characteristics

Parameters	Symbol	Typ.	Unit
Dielectric Strength	V_D	4.2	kV(50 Hz, 1 min)
Insulation Resistance	R_{IS}	1000	$M\Omega$
Creepage Distance	d_{CP}	7.2	mm
Clearance	d_{CL}	7.2	mm
Ambient Operating Temperature	T_A	-40 to +85	$^{\circ}C$
Ambient Storage Temperature	T_{STG}	-50 to +105	$^{\circ}C$
Mass	m	12	g

Catalogue

1. TMR7304-B Specifications	03
2. TMR7304-C Specifications	04
3. TMR7304-D Specifications	05
4. TMR7304-E Specifications	06
5. Typical Output Characteristics	07
6. Typical Temperature Characteristics	08
7. Parameters Definition And Formula	10
8. Application Information	11
9. Dimensions	12

1. TMR7304-B Specifications

$T_A = +25\text{ }^\circ\text{C}$, $V_{CC} = 5\text{ V}$, $R_L = 10\text{ k}\Omega$, unless otherwise noted

Parameter	Symbol	Condition	Min.	Typ.	Max.	Unit		
General Electrical Data								
Primary Nominal Current	I_{PN}	TMR7304-0060B	-	6	-	A		
		TMR7304-0150B	-	15	-			
		TMR7304-0250B	-	25	-			
		TMR7304-0500B	-	50	-			
Primary Current Measuring Range	I_{PM}	TMR7304-0060B	-20	-	20	A		
		TMR7304-0150B	-51	-	51			
		TMR7304-0250B	-85	-	85			
		TMR7304-0500B	-150	-	150			
Sensitivity	S	$I_P = 0\text{ to } \pm I_{PN}$	TMR7304-0060B	-	104.2	-	mV/A	
			TMR7304-0150B	-	41.67	-		
			TMR7304-0250B	-	25	-		
			TMR7304-0500B	-	12.5	-		
Supply Voltage	V_{CC}	$\pm 5\%$	-	5	-	V		
Offset Voltage	V_{OFF}	-	2.490	2.5	2.510	V		
Output Voltage	V_{OUT}	$I_P = 0\text{ to } \pm I_{PM}$	-	$V_{OFF} + S \times I_P$	-	V		
Current Consumption	I_C	$I_P = 0$	-	-	20	mA		
Static Performance Data								
Accuracy	X_G	$T_A = 85\text{ }^\circ\text{C}$, $I_P = 0\text{ to } \pm I_{PN}$	$T_A = 25\text{ }^\circ\text{C}$, $I_P = 0\text{ to } \pm I_{PN}$		-	± 0.8	-	% I_{PN}
			TMR7304-0060B	-	1.4	-		
			TMR7304-0150B	-	1.2	-		
			TMR7304-0250B	-	1.15	-		
			TMR7304-0500B	-	1.1	-		
Linearity	ϵ_L	$I_P = 0\text{ to } \pm I_{PN}$	-	0.3	-	% I_{PN}		
Symmetry	ϵ_{SYM}	$T_A = -40\text{ }^\circ\text{C to } +85\text{ }^\circ\text{C}$, $I_P = 0\text{ to } \pm I_{PN}$	99	100	101	%		
Dynamic Performance Data								
Response Time	t_R	$di/dt > 50\text{ A}/\mu\text{s}$, 10% to 90% of I_{PN}	-	1	-	μs		
Bandwidth	BW	-3 dB	DC	300	-	kHz		

2. TMR7304-C Specifications

$T_A = +25\text{ }^\circ\text{C}$, $V_{CC} = 5\text{ V}$, $R_L = 10\text{ k}\Omega$, unless otherwise noted

Parameter	Symbol	Condition	Min.	Typ.	Max.	Unit	
General Electrical Data							
Primary Nominal Current	I_{PN}	TMR7304-0060C	-	6	-	A	
		TMR7304-0150C	-	15	-		
		TMR7304-0250C	-	25	-		
		TMR7304-0500C	-	50	-		
Primary Current Measuring Range	I_{PM}	TMR7304-0060C	-20	-	20	A	
		TMR7304-0150C	-51	-	51		
		TMR7304-0250C	-85	-	85		
		TMR7304-0500C	-150	-	150		
Sensitivity	S	$I_P = 0\text{ to } \pm I_{PN}$	TMR7304-0060C	-	104.2	-	mV/A
			TMR7304-0150C	-	41.67	-	
			TMR7304-0250C	-	25	-	
			TMR7304-0500C	-	12.5	-	
Supply Voltage	V_{CC}	$\pm 5\%$	-	5	-	V	
Reference Output Voltage	V_{REF}	-	2.485	2.5	2.515	V	
Offset Voltage	V_{OFF}	-	-	2.5	-	V	
Output Voltage	V_{OUT}	$I_P = 0\text{ to } \pm I_{PM}$	-	$V_{OFF} + S \times I_P$	-	V	
Current Consumption	I_C	$I_P = 0$	-	-	20	mA	
Static Performance Data							
Accuracy	X_G	$T_A = 25\text{ }^\circ\text{C}$, $I_P = 0\text{ to } \pm I_{PN}$	-	± 0.8	-	% I_{PN}	
			TMR7304-0060C	-	1.4		-
		$T_A = 85\text{ }^\circ\text{C}$, $I_P = 0\text{ to } \pm I_{PN}$	TMR7304-0150C	-	1.2		-
			TMR7304-0250C	-	1.15		-
			TMR7304-0500C	-	1.1		-
Linearity	ϵ_L	$I_P = 0\text{ to } \pm I_{PN}$	-	0.3	-	% I_{PN}	
Symmetry	ϵ_{SYM}	$T_A = -40\text{ }^\circ\text{C to } +85\text{ }^\circ\text{C}$, $I_P = 0\text{ to } \pm I_{PN}$	99	100	101	%	
Offset Error	V_{OE}	$T_A = +25\text{ }^\circ\text{C}$, $I_P = 0$	-5	-	5	mV	
Dynamic Performance Data							
Response Time	t_R	$di/dt > 50\text{ A}/\mu\text{s}$, 10% to 90% of I_{PN}	-	1	-	μs	
Bandwidth	BW	-3 dB	DC	300	-	kHz	

3. TMR7304-D Specifications

$T_A = +25\text{ }^\circ\text{C}$, $V_{CC} = 5\text{ V}$, $R_L = 10\text{ k}\Omega$, unless otherwise noted

Parameter	Symbol	Condition	Min.	Typ.	Max.	Unit	
General Electrical Data							
Primary Nominal Current	I_{PN}	TMR7304-0060D	-	6	-	A	
		TMR7304-0150D	-	15	-		
		TMR7304-0250D	-	25	-		
		TMR7304-0500D	-	50	-		
Primary Current Measuring Range	I_{PM}	TMR7304-0060D	-20	-	20	A	
		TMR7304-0150D	-51	-	51		
		TMR7304-0250D	-85	-	85		
		TMR7304-0500D	-150	-	150		
Sensitivity	S	$I_P = 0\text{ to } \pm I_{PN}$	TMR7304-0060D	-	104.2	-	mV/A
			TMR7304-0150D	-	41.67	-	
			TMR7304-0250D	-	25	-	
			TMR7304-0500D	-	12.5	-	
Supply Voltage	V_{CC}	$\pm 5\%$	-	5	-	V	
Reference Output Voltage	V_{REF}	-	2.485	2.5	2.515	V	
Offset Voltage	V_{OFF}	-	-	2.5	-	V	
Output Voltage	V_{OUT}	$I_P = 0\text{ to } \pm I_{PM}$	-	$V_{OFF} + S \times I_P$	-	V	
Current Consumption	I_C	$I_P = 0$	-	-	20	mA	
Static Performance Data							
Accuracy	X_G	$T_A = 25\text{ }^\circ\text{C}$, $I_P = 0\text{ to } \pm I_{PN}$	-	± 0.8	-	% I_{PN}	
			TMR7304-0060D	-	1.4		-
		$T_A = 85\text{ }^\circ\text{C}$, $I_P = 0\text{ to } \pm I_{PN}$	TMR7304-0150D	-	1.2		-
			TMR7304-0250D	-	1.15		-
			TMR7304-0500D	-	1.1		-
Linearity	ϵ_L	$I_P = 0\text{ to } \pm I_{PN}$	-	0.3	-	% I_{PN}	
Symmetry	ϵ_{SYM}	$T_A = -40\text{ }^\circ\text{C to } +85\text{ }^\circ\text{C}$, $I_P = 0\text{ to } \pm I_{PN}$	99	100	101	%	
Offset Error	V_{OE}	$T_A = +25\text{ }^\circ\text{C}$, $I_P = 0$	-5	-	5	mV	
Dynamic Performance Data							
Response Time	t_R	$di/dt > 50\text{ A}/\mu\text{s}$, 10% to 90% of I_{PN}	-	1	-	μs	
Bandwidth	BW	-3 dB	DC	300	-	kHz	

4. TMR7304-E Specifications

$T_A = +25\text{ }^\circ\text{C}$, $V_{CC} = 5\text{ V}$, $R_L = 10\text{ k}\Omega$, unless otherwise noted

Parameter	Symbol	Condition	Min.	Typ.	Max.	Unit
General Electrical Data						
Primary Nominal Current	I_{PN}	TMR7304-0750E	-	75	-	A
Primary Current Measuring Range	I_{PM}	TMR7304-0750E	-180	-	180	A
Sensitivity	S	$I_P = 0$ to $\pm I_{PN}$	-	6.25	-	mV/A
Supply Voltage	V_{CC}	$\pm 5\%$	-	5	-	V
Reference Output Voltage	V_{REF}	-	2.485	2.5	2.515	V
Offset Voltage	V_{OFF}	-	-	2.5	-	V
Output Voltage	V_{OUT}	$I_P = 0$ to $\pm I_{PM}$	-	$V_{OFF} + S \times I_P$	-	V
Current Consumption	I_C	$I_P = 0$	-	-	20	mA
Static Performance Data						
Accuracy	X_G	$T_A = 25\text{ }^\circ\text{C}$, $I_P = 0$ to $\pm I_{PN}$	-	± 0.8	-	% I_{PN}
		$T_A = 85\text{ }^\circ\text{C}$, $I_P = 0$ to $\pm I_{PN}$	-	1.1	-	
Linearity	ϵ_L	$I_P = 0$ to $\pm I_{PN}$	-	0.3	-	% I_{PN}
Symmetry	ϵ_{SYM}	$T_A = -40\text{ }^\circ\text{C}$ to $+85\text{ }^\circ\text{C}$, $I_P = 0$ to $\pm I_{PN}$	99	100	101	%
Offset Error	V_{OE}	$T_A = +25\text{ }^\circ\text{C}$, $I_P = 0$	-5	-	5	mV
Dynamic Performance Data						
Response Time	t_R	$di/dt > 50\text{ A}/\mu\text{s}$, 10% to 90% of I_{PN}	-	1	-	μs
Bandwidth	BW	-3 dB	DC	300	-	kHz

5. Typical Output Characteristics

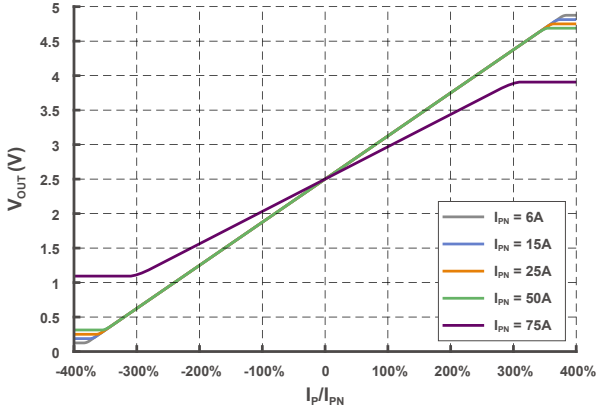

Figure 1. Output Voltage vs Primary Current

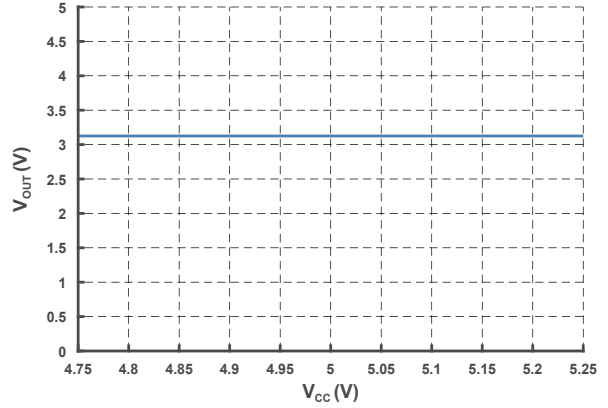

Figure 2. Output Voltage vs Supply Voltage (@ $I_P = I_{PN}$)

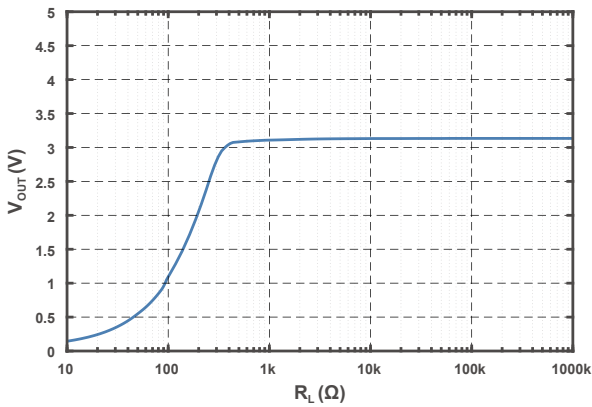

Figure 3. Output Voltage vs Load Resistance (@ $I_P = I_{PN}$)

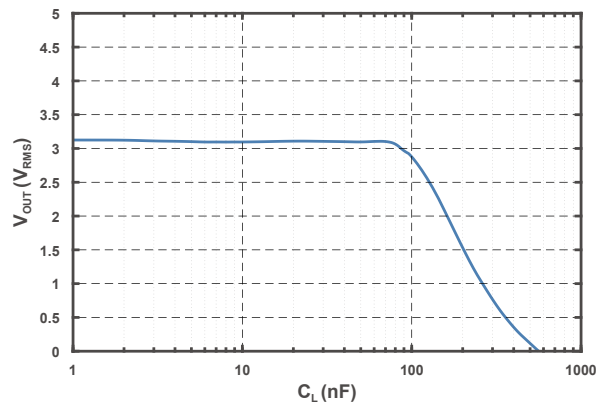

Figure 4. Output Voltage vs Load Capacitance (@ $I_P = I_{PN}$)

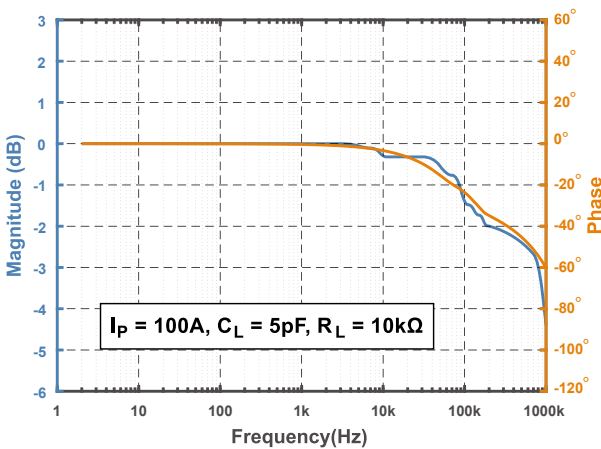

Figure 5. Bode Plot

6. Typical Temperature Characteristics



 AVG+3σ AVG AVG-3σ

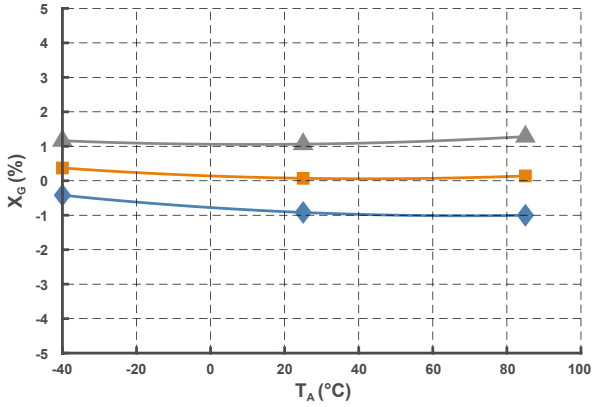

Figure 6. Accuracy

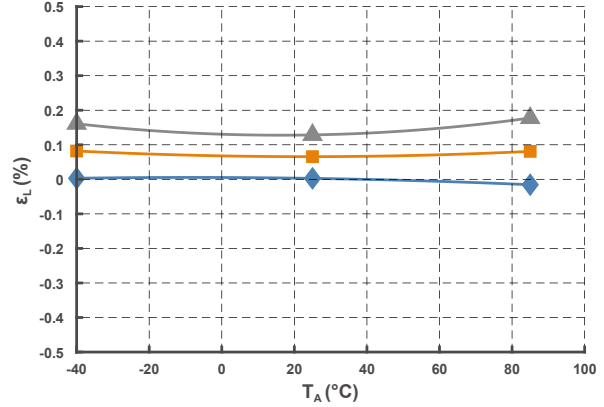

Figure 7. Linearity

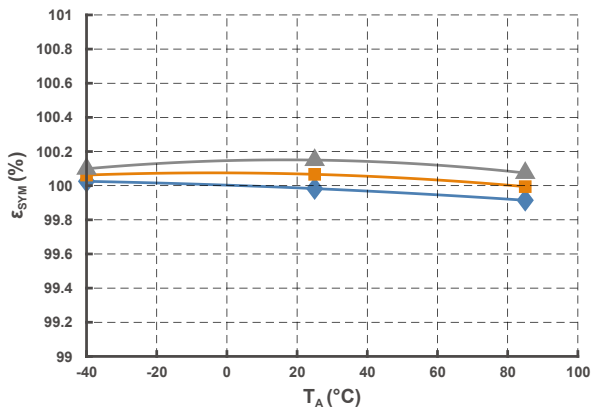

Figure 8. Symmetry

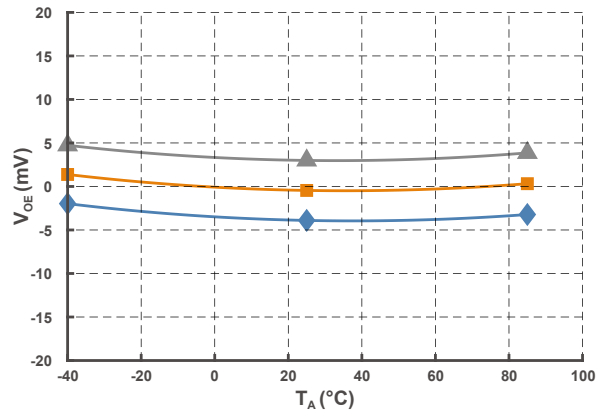

Figure 9. Offset Error

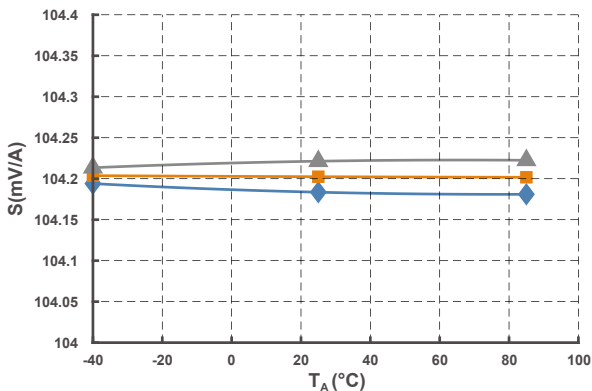

Figure 10. Sensitivity (@I_{PN} = 6 A)

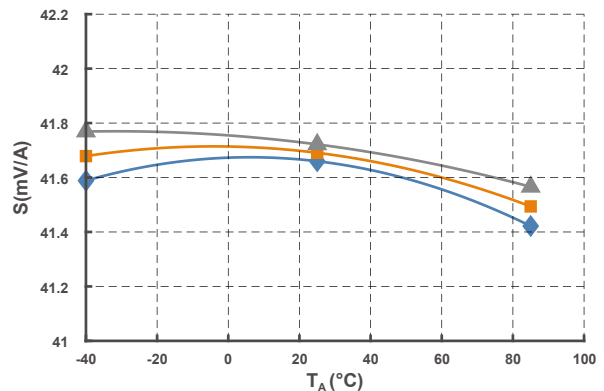

Figure 11. Sensitivity (@I_{PN} = 15 A)

Typical Temperature Characteristics

▲ AVG+3σ ■ AVG ◆ AVG-3σ

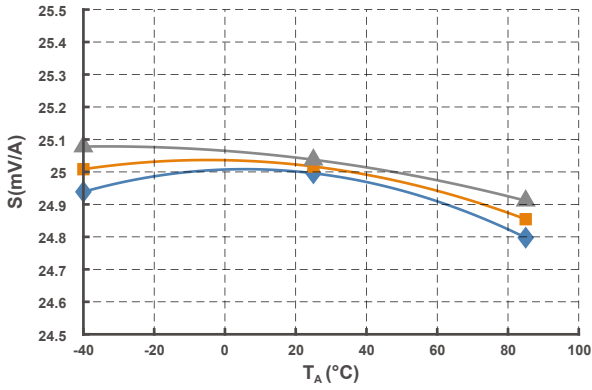

Figure 12. Sensitivity (@I_{PN} = 25 A)

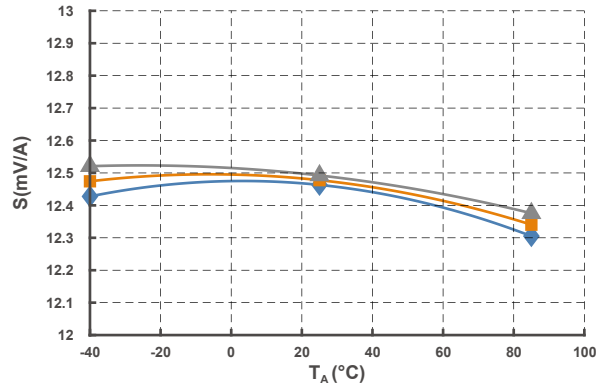

Figure 13. Sensitivity (@I_{PN} = 50 A)

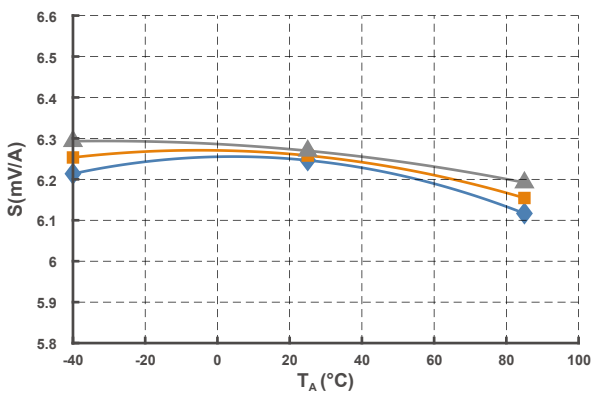

Figure 14. Sensitivity (@I_{PN} = 75 A)

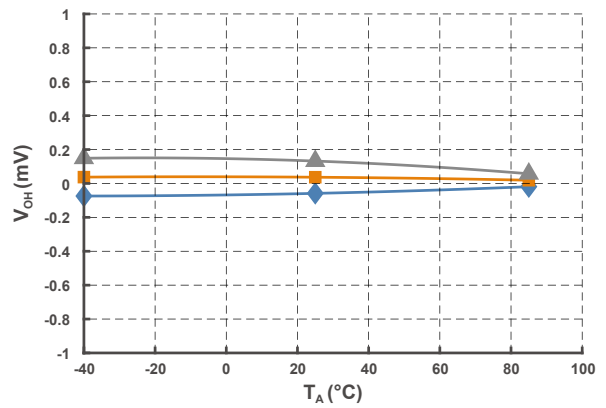

Figure 15. Hysteresis

7. Parameters Definition And Formula

1) Output Voltage

$$V_{OUT} = V_{OFF} + S \times I_P$$

V_{OUT} stands for current sensor output voltage at given primary current, V_{OFF} stands for offset voltage, S stands for sensitivity, I_P stands for primary current.

2) Accuracy

$$X_G = \text{MAX}_{I_P \in [-I_{PN}, I_{PN}]} \left(\frac{(V_{OUT} - V_{REF}) - (S \times I_P)}{S \times I_{PN}} \times 100\% \right)$$

I_{PN} stands for nominal primary current

3) Sensitivity

$$S = \frac{V_{OUT(@ I_{PN})} - V_{OUT(@ -I_{PN})}}{2 \times I_{PN}}$$

$V_{OUT(@ I_{PN})}$ and $V_{OUT(@ -I_{PN})}$ stand for the current output at I_{PN} and $-I_{PN}$ respectively.

4) Linearity

$$\varepsilon_L = \text{MAX}_{I_P \in [-I_{PN}, I_{PN}]} \left(\frac{(V_{OUT} - V_{REF}) - (\bar{V}_{OE} + \bar{S} \times I_P)}{S \times I_{PN}} \times 100\% \right)$$

\bar{S} and \bar{V}_{OE} stand for the average values of the sensitivity and electric offset.

5) Symmetry

$$\varepsilon_{SYM} = \left| \frac{V_{OUT(@ I_{PN})} - \bar{V}_{OFF}}{V_{OUT(@ -I_{PN})} - \bar{V}_{OFF}} \right| \times 100\%$$

6) Hysteresis

$$V_{OH} = \text{MAX } \Delta H$$

ΔH is the maximum residual output current between full scale positive and negative nominal current.

7) Offset Voltage

$$V_{OE} = V_{OUT(@ I_P = 0)} - V_{REF}$$

8. Application Information

Electrical Connection

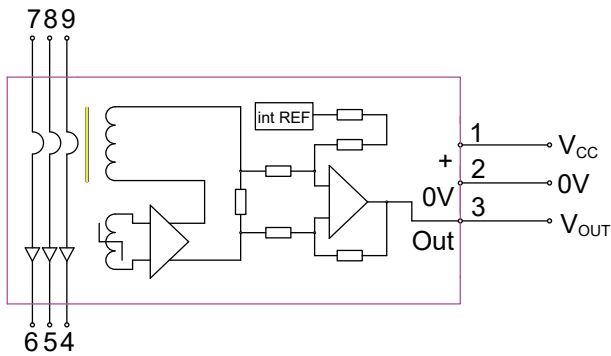

Figure 16. TMR7304-B Electrical Connection

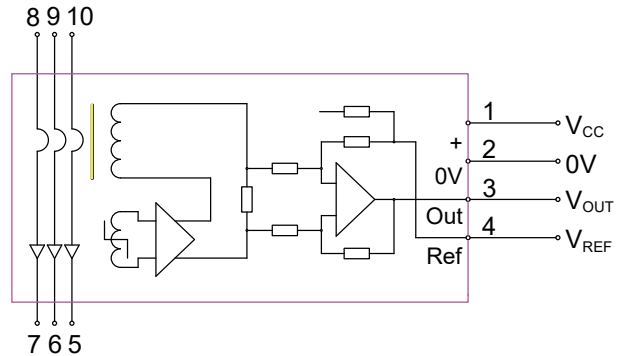

Figure 17. TMR7304-C Electrical Connection

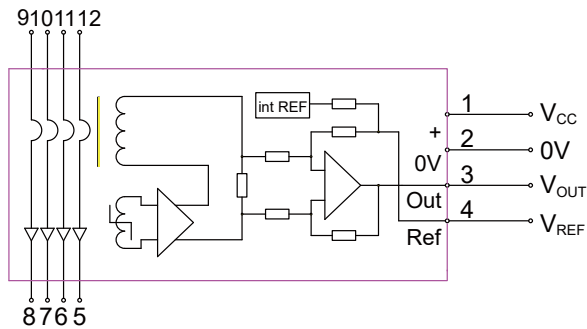

Figure 18. TMR7304-D Electrical Connection

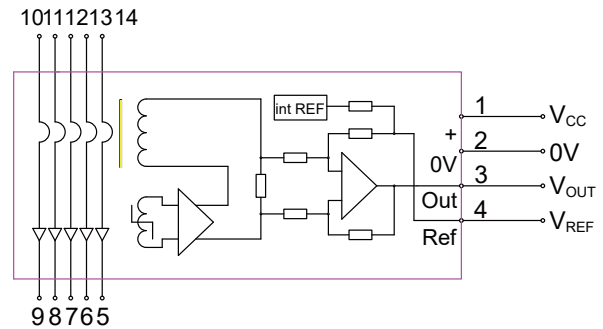

Figure 19. TMR7304-E Electrical Connection

Remarks

1. V_{OUT} is positive when the primary current (I_p) is in the same direction as the arrow indication on the label and vice versa.
2. Improper connection may result in permanent damage of the sensor.
3. Excessive capacitive load may result in distortion of output signals when measuring high frequency primary signal. Please refer to Output Voltage vs Load Capacitance Curve.
4. Wave soldering profile max temperature should be set no higher than 260 °C for 10 s.
5. Sensor is customizable upon request.

9. Dimensions

Dimension for TMR7304-B Series

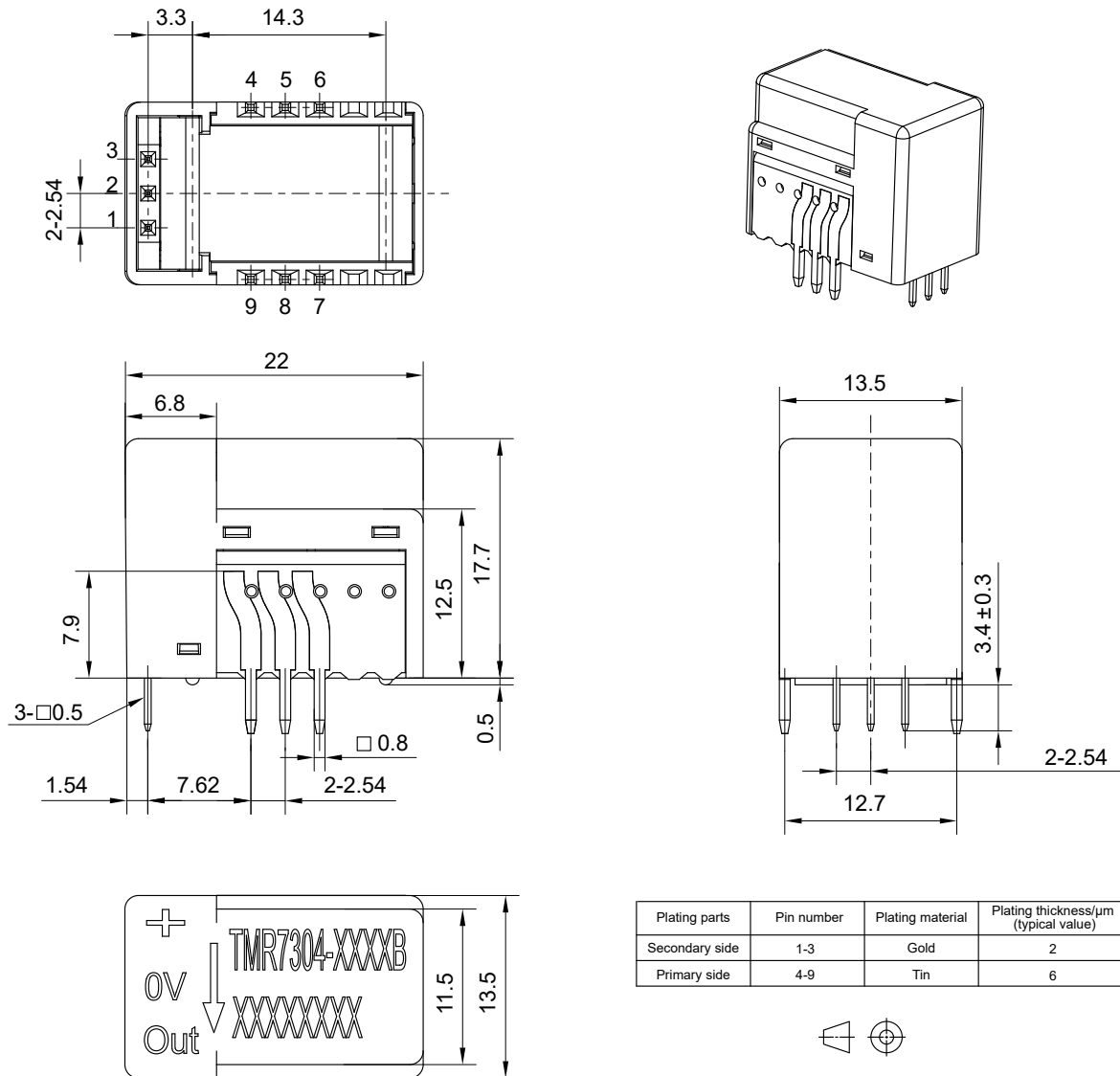

Figure 20. Dimension for TMR7304-B (unit: mm, tolerances for unmarked scales ± 1 mm)

Dimension for TMR7304-C Series

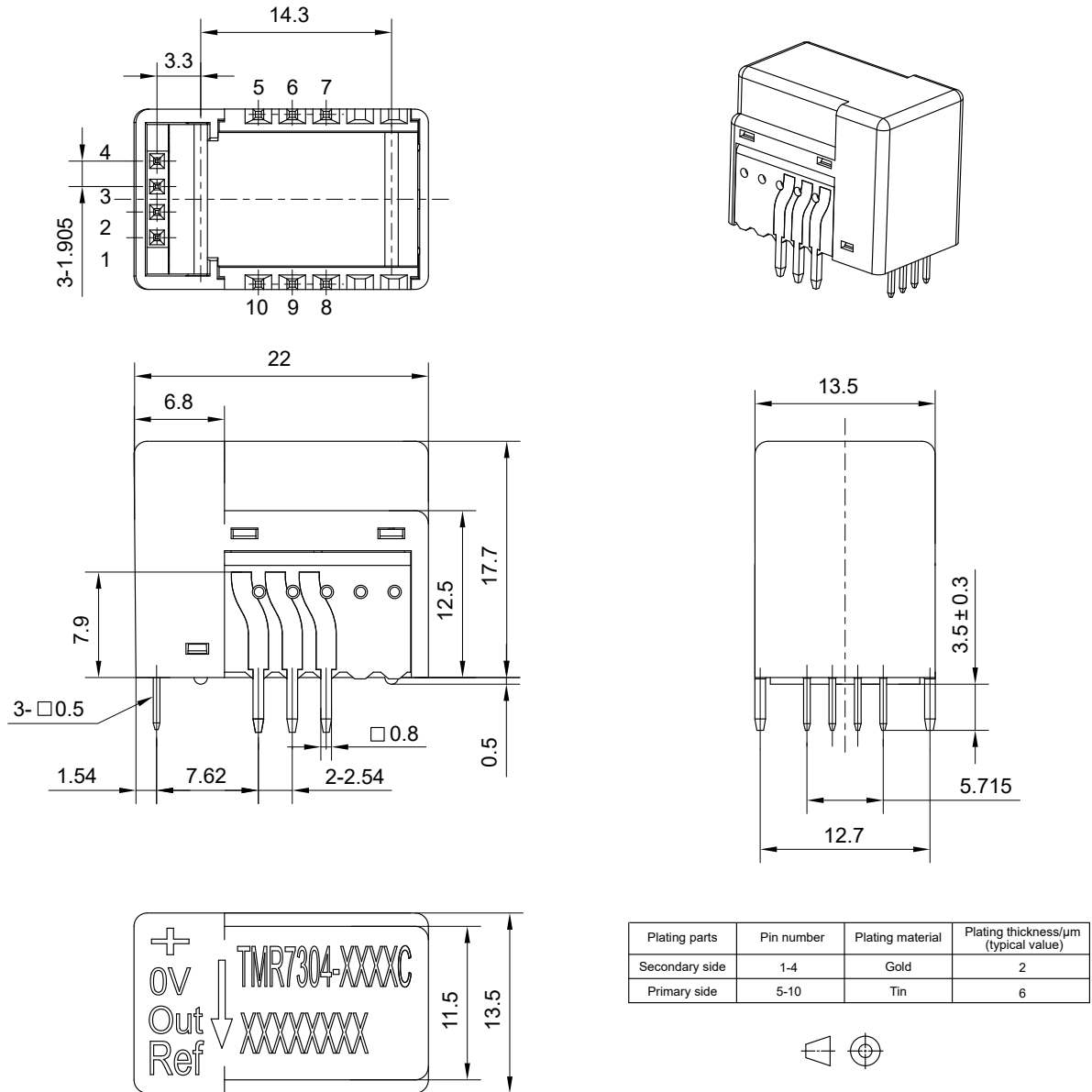

Figure 21. Dimension for TMR7304-C (unit: mm, tolerances for unmarked scales ± 1 mm)

Dimension for TMR7304-D Series

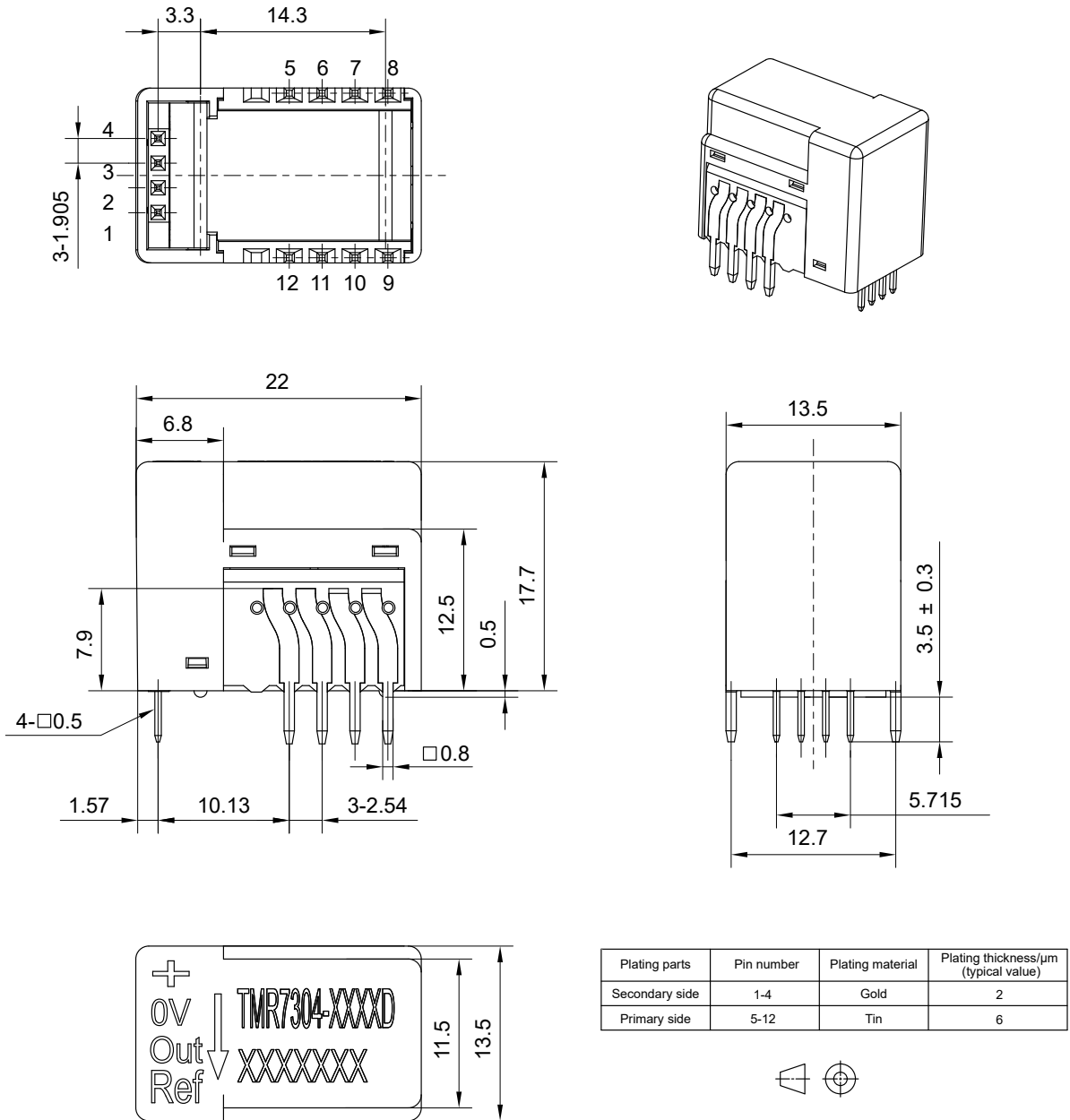

Figure 22. Dimension for TMR7304-D (unit: mm, tolerances for unmarked scales ± 1 mm)

Dimension for TMR7304-E

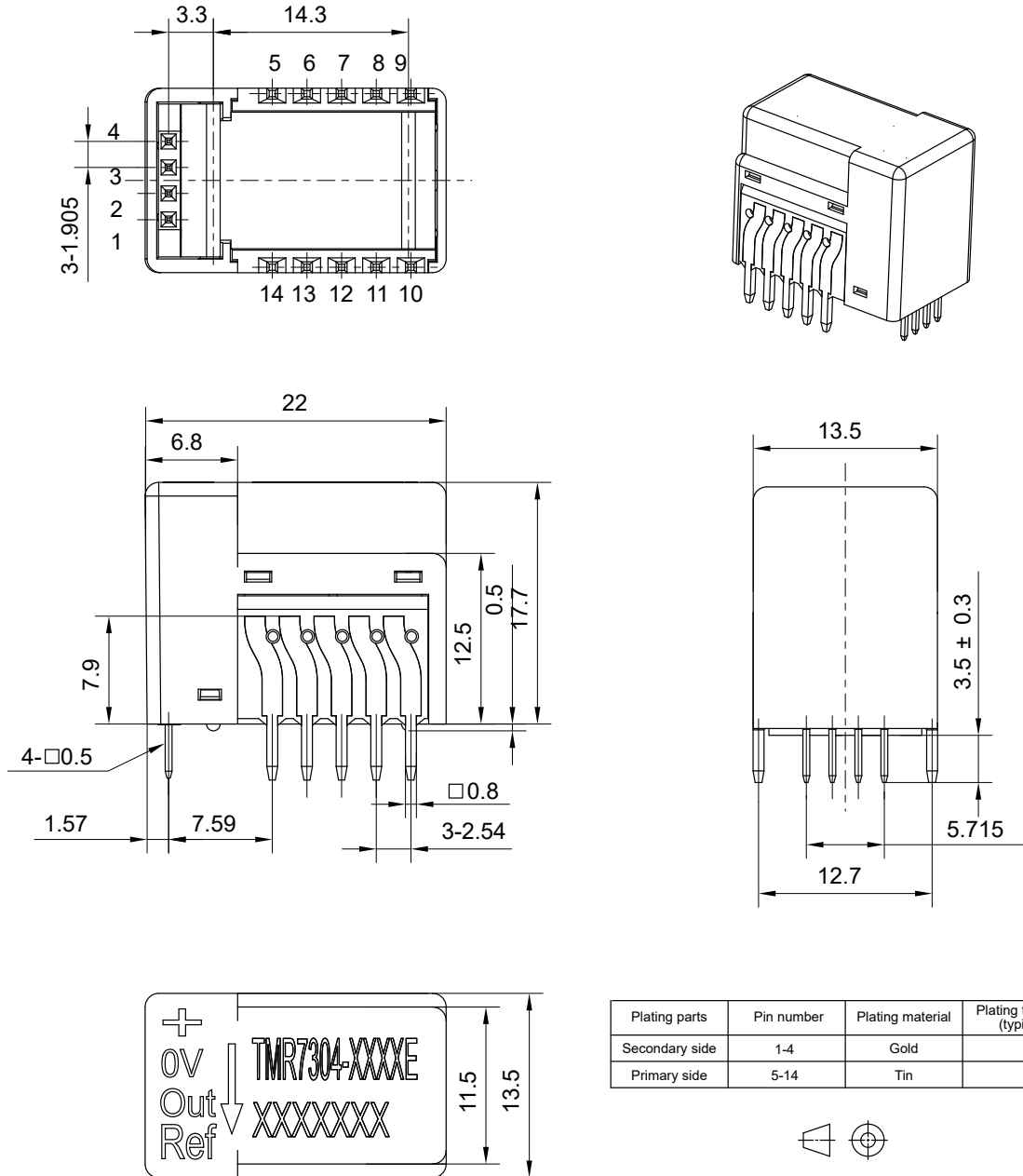

Figure 23. Dimension for TMR7304-E (unit: mm, tolerances for unmarked scales ± 1 mm)

Copyright © 2025 by MultiDimension Technology Co., Ltd.

Information furnished herein by MultiDimension Technology Co., Ltd. (hereinafter MDT) is believed to be accurate and reliable. However, MDT disclaims any and all warranties and liabilities of any kind, with respect to any examples, hints or any performance or use of technical data as described herein and/or any information regarding the application of the product, including without limitation warranties of non-infringement of intellectual property rights of any third party. This document neither conveys nor implies any license under patent or other industrial or intellectual property rights. Customer or any third-party must further determine the suitability of the MDT products for its applications to avoid the applications default of customer or third-party. MDT accept no liability in this respect.

MDT does not assume any liabilities of any indirect, incidental, punitive, special or consequential damages (including without limitation of lost profits, lost savings, business interruption, costs related to the removal or replacement of any products or rework charges) whether or not such damages are based on tort (including negligence), warranty, breach of contract or any other legal theory. Notwithstanding any damages that customer might incur for any reason whatsoever, MDT's aggregate and cumulative liability towards customer for the products described herein shall be limited in accordance with the terms and conditions of commercial sale of MDT.

Absolute maximum ratings are the extreme limits the device will withstand without damage to the MDT product. However, the electrical and mechanical characteristics are not guaranteed as the maximum limits (above recommended operating conditions) are approached. MDT disclaims any and all warranties and liabilities of the MDT product will operate at absolute maximum ratings.

Specifications may change without notice.

Please download latest document from our official website www.dowaytech.com/en.

Recycling

The product(s) in this document need to be handed over to a qualified solid waste management services company for recycling in accordance with relevant regulations on waste classification after the end of the product(s) life.



No.2 Guangdong Road, Zhangjiagang Free Trade Zone, Jiangsu, China

Web: www.dowaytech.com/en E-mail: info@dowaytech.com

