

TMR1262

Nano-Ampere Bipolar Latching Magnetic Switch Sensor

Description

The TMR1262 is a bipolar open-drain magnetic switch sensor that integrates TMR sensors with CMOS circuitry, converting magnetic field strength into digital voltage outputs.

The TMR1262 achieves a magnetic signal response frequency of 50 Hz with an ultra-low static supply current of 200 nA, making it suitable for low-power applications. Compared to Hall and AMR sensors operating in power-cycling modes, the TMR1262 offers higher response frequency and faster response time at a similar power level across wide operating temperature range.

The TMR1262 operates over a supply voltage range of 1.8 V to 5.5 V with excellent temperature stability. It is available in SOT23-3 (TMR1262S) and TO92S (TMR1262T) packages, providing flexible integration options.



SOT23-3

TO92S

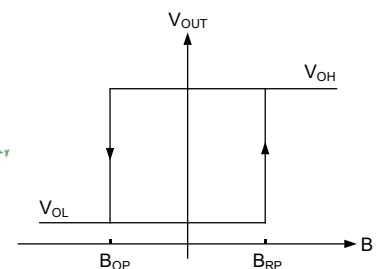
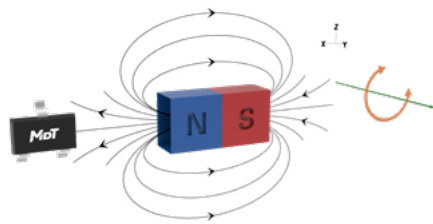
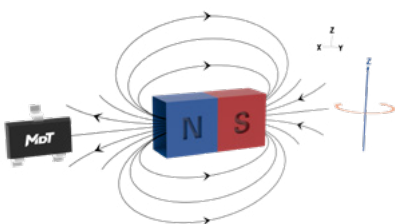

Features and Benefits

- Tunneling magnetoresistance (TMR) technology
- Low power consumption: supply current 200 nA
- Frequency response: 50 Hz
- Bipolar latching operation
- CMOS push-pull output
- High sensitivity
- Wide range supply voltages: 1.8 V to 5.5 V
- Excellent temperature stability
- High tolerance to external magnetic field interference
- RoHS & REACH compliant

Applications

- Utility meters: water, gas, and heat meters
- Solid-state switch
- Speed sensing
- Linear and rotation position sensing

Selection Guide

Part Number	Supply Current	Response Frequency	Operating Ambient Temperature	Operating Point	Release Point	Package	Packing Form
TMR1262S	200 nA	50 Hz	-40 °C to 125 °C	-17 Gs	17 Gs	SOT23-3	Tape & Reel
TMR1262T	200 nA	50 Hz	-40 °C to 125 °C	-17 Gs	17 Gs	TO92S	ESD Bag

Note: Please contact MultiDimension Technology local sales for customizing operating and release points.

Catalogue

1. Functional Block Diagram.....	03
2. Switching Characteristics	03
3. Pin Configuration	03
4. Absolute Maximum Ratings	04
5. Electrical Specifications.....	04
6. Magnetic Specifications.....	04
7. Typical Supply Voltage Characteristics.....	05
8. Typical Temperature Characteristics	05
9. Application Information	06
10. Dimensions.....	07

1. Functional Block Diagram

The TMR1262 series switch sensor is composed of TMR sensors and signal processing circuits. The TMR sensor detects external magnetic field, generates an analog voltage signal, and outputs a logical switch level after processing by the circuit as shown in Figure 1.

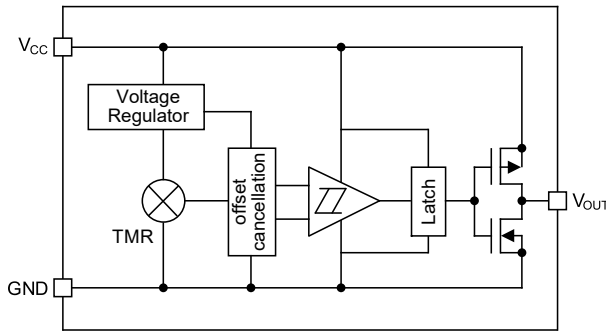

Figure 1. Block diagram

2. Switching Characteristics

TMR1262 sensing axis is parallel to the package top-marking surface; the sensing axis is defined from the N pole toward the S pole, as indicated by the arrow in the figure below.

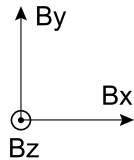

Figure 2-1. Definition of axis

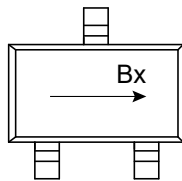

Figure 2-2. Axial diagram (SOT23-3 top view)

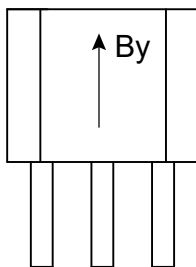

Figure 2-3. Axial diagram (TO92S side view)

The output is “High”, when power is on at zero magnetic field. B is the external magnetic field along the sensing direction, B_{OP} is the operating point, B_{RP} is the release point, and hysteresis B_H is define as the difference between B_{OP} and B_{RP} .

The sensor outputs a low level, when the magnetic field along the sensing axis exceeds the operate point B_{OP} , and the device outputs a high level, when the magnetic field is reduced below the release point B_{RP} as shown in Figure 3.

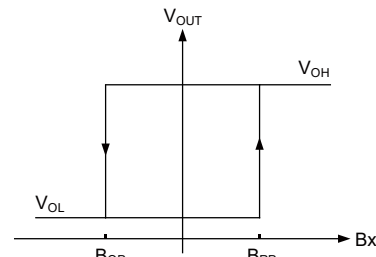

Figure 3-1. Switching characteristics (SOT23-3)

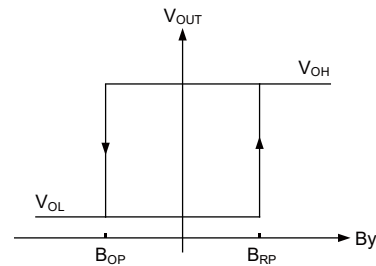

Figure 3-2. Switching characteristics (TO92S)

3. Pin Configuration

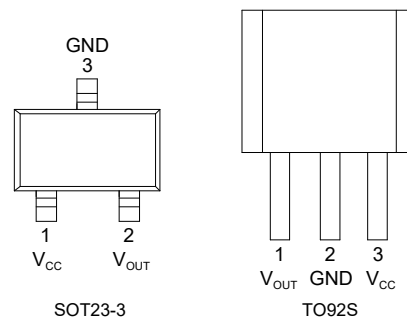

Figure 4. Pin configuration

Pin Number		Name	Function
SOT23-3	TO92S		
1	3	V_{CC}	Power supply
2	1	V_{OUT}	Output
3	2	GND	Ground

4. Absolute Maximum Ratings

Parameters	Symbol	Min.	Max.	Unit
Supply voltage	V_{CC}	-	7	V
Reverse supply voltage	V_{RCC}	-	0.3	V
Output current	$I_{OUTSINK}$	-	9	mA
Magnetic flux density	B	-	4000	Gs
ESD performance (HBM)	V_{ESD}	-	4	kV
Operating ambient temperature	T_A	-40	125	°C
Storage ambient temperature	T_{STG}	-50	150	°C

5. Electrical Specifications

$V_{CC} = 3.0\text{ V}$, $T_A = 25\text{ °C}$, a $0.1\text{ }\mu\text{F}$ capacitor is connected between V_{CC} and GND

Parameter	Symbol	Condition	Min.	Typ.	Max.	Unit
Supply voltage	V_{CC}	Operating	1.8	3.0	5.5	V
Output high voltage	V_{OH}	-	$V_{CC}-0.3$	-	V_{CC}	V
Output low voltage	V_{OL}	-	-	-	0.2	V
Supply current	I_{CC}	Output open	-	200	-	nA
Response frequency	F	-	-	50	-	Hz

6. Magnetic Specifications

$V_{CC} = 3.0\text{ V}$, $T_A = 25\text{ °C}$, a $0.1\text{ }\mu\text{F}$ capacitor is connected between V_{CC} and GND

Parameter	Symbol	Min.	Typ.	Max.	Unit
Operate point	B_{OP}	-25	-	-10	Gs
Release point	B_{RP}	10	-	25	Gs
Hysteresis	B_H	20	-	50	Gs

7. Typical Supply Voltage Characteristics

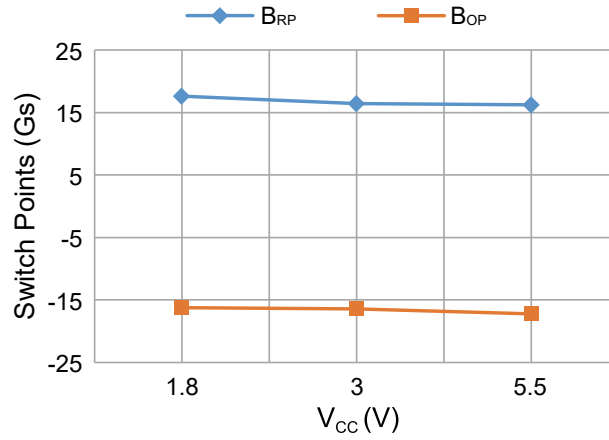

Figure 5. Switch points versus supply voltage ($T_A=25^\circ\text{C}$)

8. Typical Temperature Characteristics

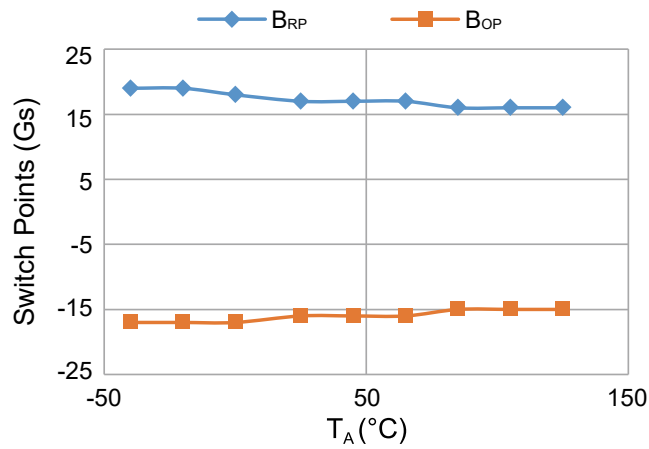

Figure 6. Switch points versus temperature ($V_{CC} = 3 \text{ V}$)

9. Application Information

It is recommended to add a filter capacitor between the sensor power supply and ground (close to the sensor) to reduce external noise. As shown in Figure 7, the typical value is 0.1 μF .

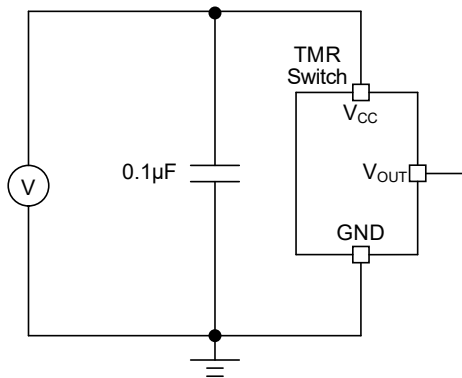

Figure 7. Application circuit diagram

The TMR1262 series sensors are not suitable for driving power loads. The general method of use is utilizing the output voltage of V_{OUT} pin as a signal to input the MCU or drive a triode or MOS as shown in Figure 8.

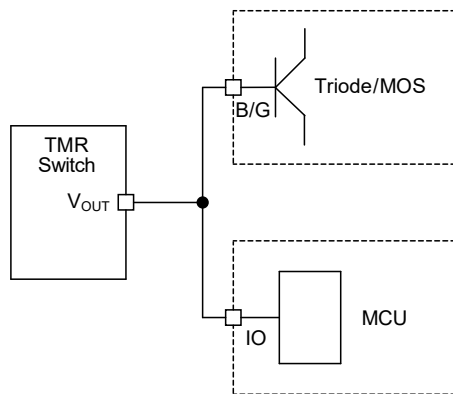

Figure 8. Application diagram for driving power load

Common failure conditions:

- The device is exposed to conditions exceeding any absolute maximum rating.
- The external circuit does not include properly matched supply-pin decoupling/filter capacitors.
- The device's V_{OUT} pin is used to directly drive power devices (e.g., relays), causing the output current to exceed the "Absolute Maximum Ratings".
- The device operates in a humid environment for an extended period.
- The maximum soldering temperature exceeds 260°C, or exposure above 250°C lasts longer than 10s.
- The device is exposed to temperatures above the maximum operating temperature while the external magnetic field exceeds 20 Gs.
- The device is exposed to an ultrasonic environment.
- Excessive deformation of the device leads/pins.
- Applying a voltage to the V_{OUT} pin, or powering the device through the V_{OUT} pin.

10. Dimensions

SOT23-3 Package

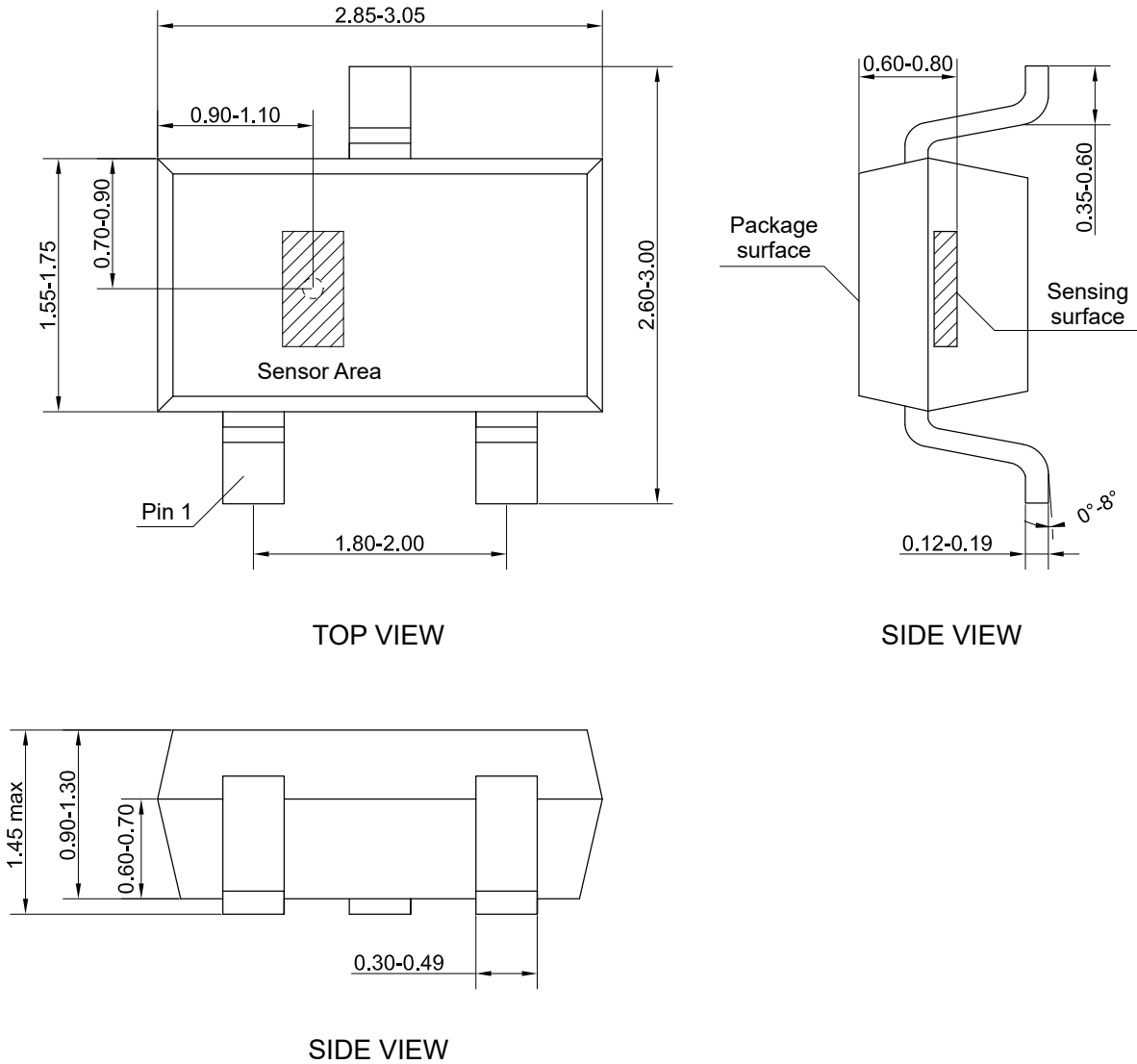

Figure 9. Package outline of SOT23-3 (unit: mm)

TO92S Package

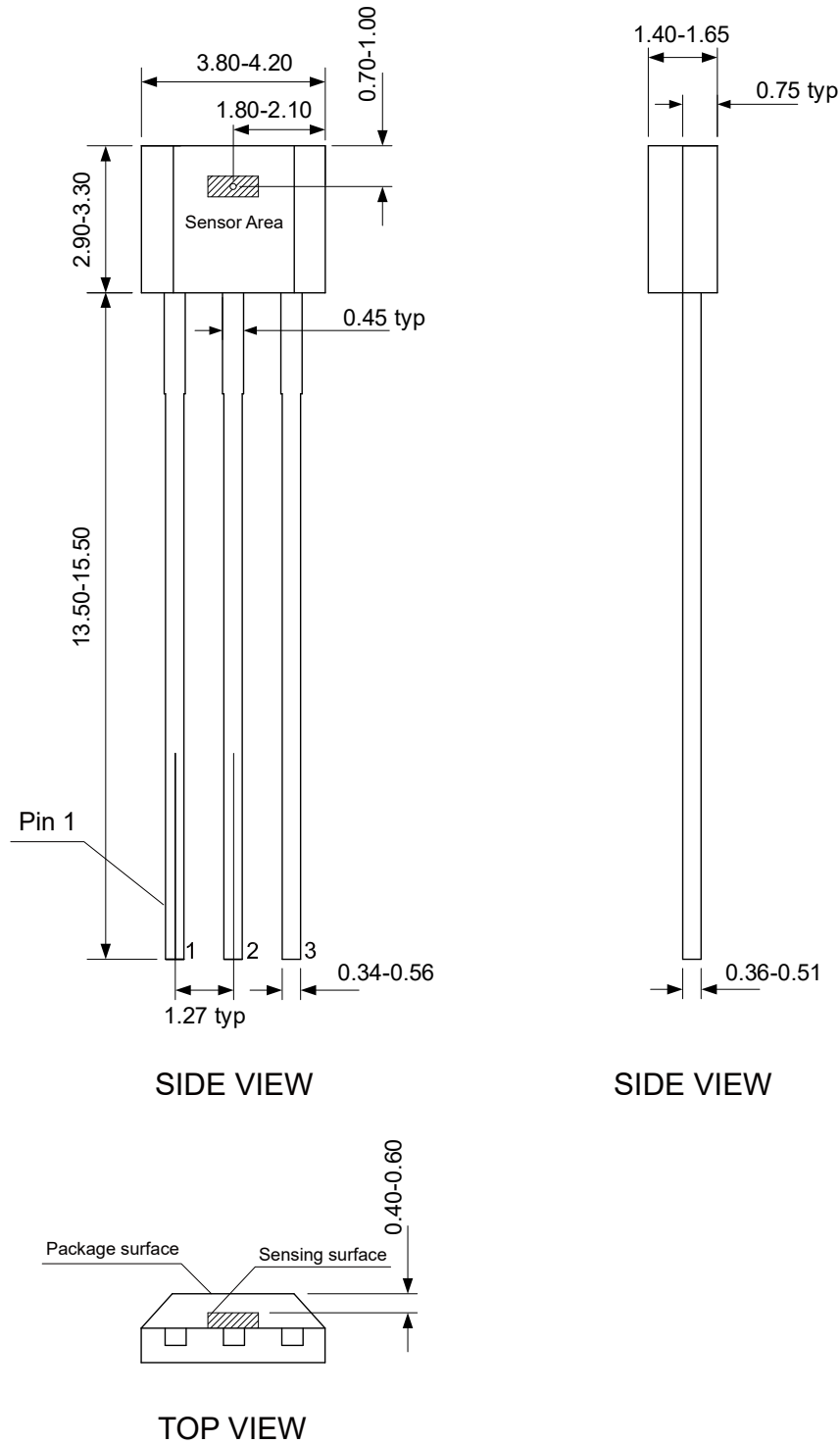

Figure 10. Package outline of TO92S (unit: mm)

Copyright © 2026 by MultiDimension Technology Co., Ltd.

Information furnished herein by MultiDimension Technology Co., Ltd. (hereinafter MDT) is believed to be accurate and reliable. However, MDT disclaims any and all warranties and liabilities of any kind, with respect to any examples, hints or any performance or use of technical data as described herein and/or any information regarding the application of the product, including without limitation warranties of non-infringement of intellectual property rights of any third party. This document neither conveys nor implies any license under patent or other industrial or intellectual property rights. Customer or any third-party must further determine the suitability of the MDT products for its applications to avoid the applications default of customer or third-party. MDT accept no liability in this respect.

MDT does not assume any liabilities of any indirect, incidental, punitive, special or consequential damages (including without limitation of lost profits, lost savings, business interruption, costs related to the removal or replacement of any products or rework charges) whether or not such damages are based on tort (including negligence), warranty, breach of contract or any other legal theory. Notwithstanding any damages that customer might incur for any reason whatsoever, MDT's aggregate and cumulative liability towards customer for the products described herein shall be limited in accordance with the terms and conditions of commercial sale of MDT.

Absolute maximum ratings are the extreme limits the device will withstand without damage to the MDT product. However, the electrical and mechanical characteristics are not guaranteed as the maximum limits (above recommended operating conditions) are approached. MDT disclaims any and all warranties and liabilities of the MDT product will operate at absolute maximum ratings.

Specifications may change without notice.

Please download latest document from our official website www.dowaytech.com/en.

Recycling

The product(s) in this document should be disposed of at the end of the product(s) life using a qualified waste management company for recycling in accordance with local regulations.



No.2 Guangdong Road, Zhangjiang Free Trade Zone, Jiangsu, China

Web: www.dowaytech.com/en E-mail: info@dowaytech.com

